

A
seminar
on
“Internet Telephony”

Presented by:

Nitin Prakash Sharma

M. Tech. I.T

IIT Kharagpur

Contents

- Introduction
- H.323 standard
- Classes of connections and billing
- Requirements for IPT Management
- Conclusion
- References

Introduction

- History

- VocalTec* introduced the first IP telephony software product in early 1995
- March of 1996, VocalTec announced to produce the first IP telephony gateway
- Gateways are the key to bringing IP telephony into the mainstream

- What is Internet telephony?

IP telephony (Internet Protocol telephony) is a general term for the technologies that use the Internet Protocol's packet-switched connections to exchange voice, fax, and other forms of information that have traditionally been carried over the dedicated circuit-switched connections of the public switched telephone network (PSTN).

Introduction

Factors making Internet telephony possible:

- Voice quality is increasing, thanks to new codec technology
- There are ongoing improvements in compression techniques
- Full-duplex PC sound cards enable two-way simultaneous calls
- The typical PC is getting more and more powerful, making it possible to perform processor-intensive functions without specialized hardware.

H.323 Standard

- What is H.323 ?
- Basic Protocols
 - RAS
 - RTP and RTCP
 - Resource Reservation Protocol (RSVP)
- Components
 - Terminals
 - Gateways
 - Gatekeeper

What is H.323 ?

H.323 Recommendation describes terminals and other entities that provide multimedia communications services over Packet Based Networks (PBN) which may not provide a guaranteed Quality of Service.

Registration/Admission/ Status (RAS)

- The RAS channel is a User Datagram Protocol (UDP)- based protocol
- Used for:
 - Endpoint Registration/ Deregistration
 - Admission Control
 - Bandwidth Change Request
 - Endpoint Status Control.

RTP and RTCP (Real-time Transport Protocol and Real-time Control Protocol)

The functions provided by RTP include:

- Sequencing
- Payload Identification
- Frame Indication
- Source Identification
- Intramedia Synchronization

The function provided by RTCP include:

- QoS feedback
- Session Control
- Identification
- Intermedia Synchronization

RSVP

- RSVP is a transport layer protocol
- It is receiver oriented
- It supports both unicast and multicast
- It maintains soft state in routers and hosts, providing graceful support for dynamic membership changes
- It provides transparent operation through routers that do not support it
- Enables a network to provide differentiated levels of service to specific flows of data

H.323 basic protocols

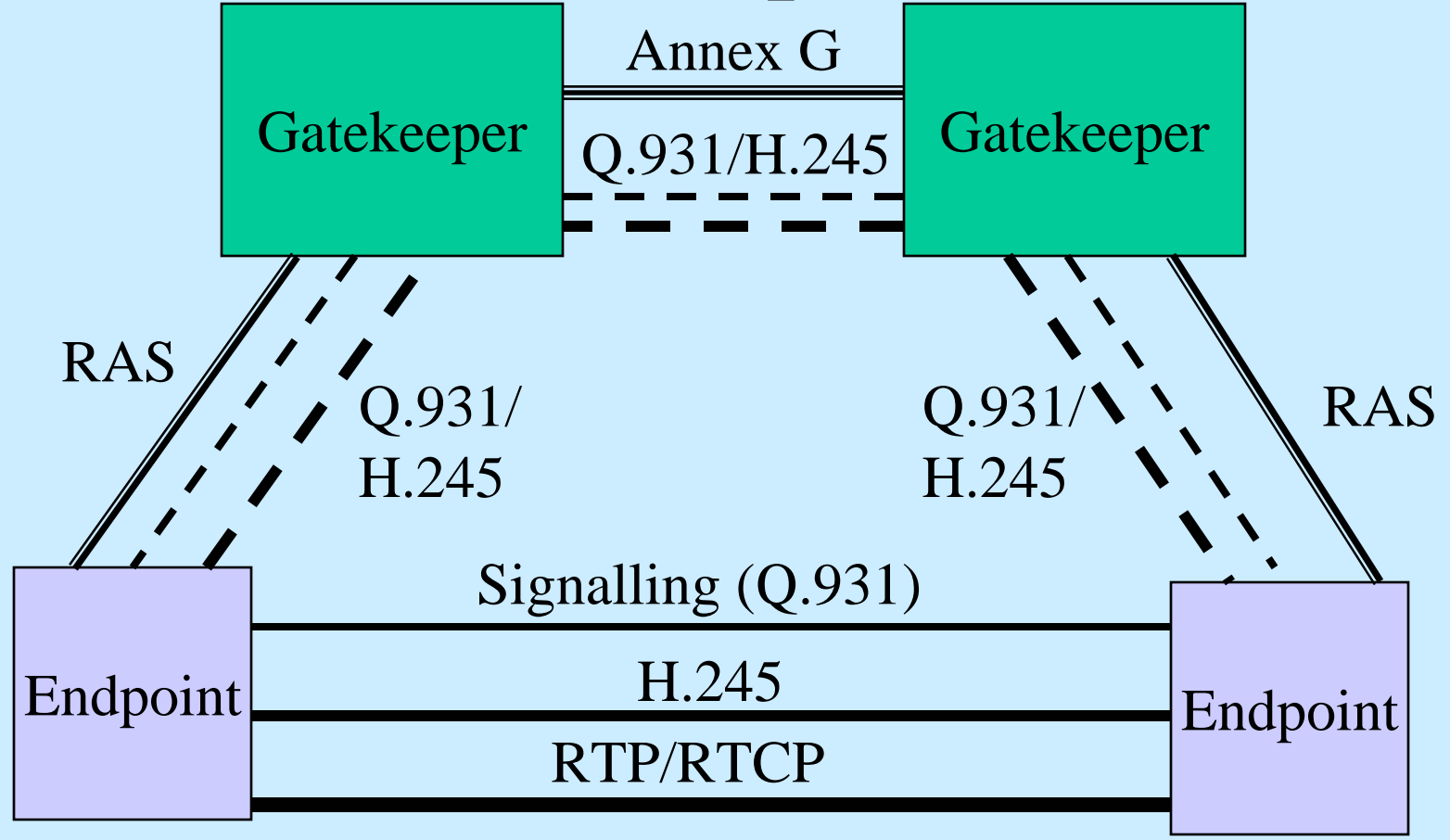

- - - Gatekeeper Routed Signaling
- Direct Routed Signaling

Component - Terminal

- H.323 terminal can be either a personal computer or a stand-alone device, running an H.323 and the multi-media applications
- Supports audio communications and optionally supports video and data communications

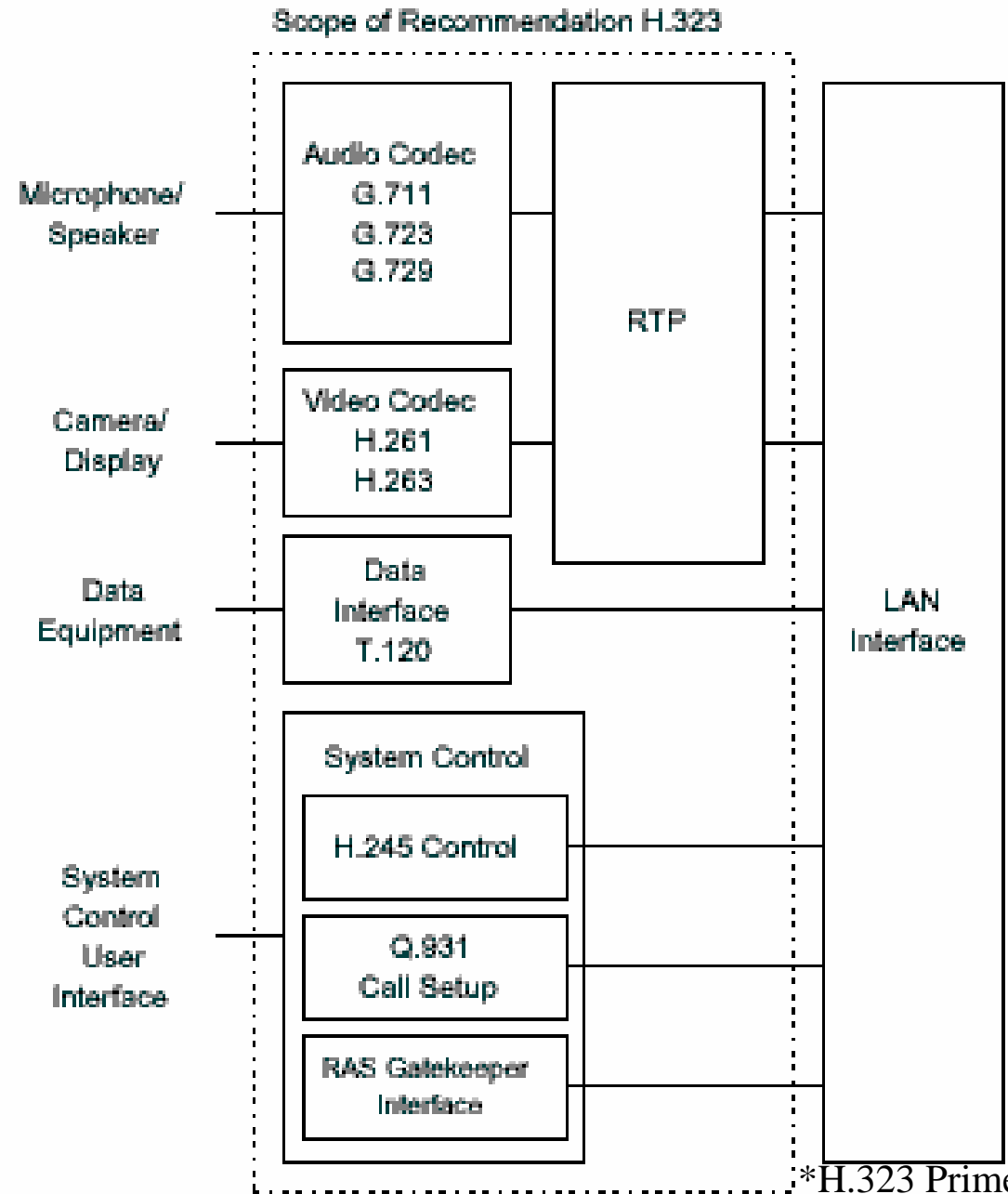

Component - GateKeeper

- Acts as the central point for all calls within its zone
- Does address translation
- Bandwidth management
- Admissions Control
- Zone Management
- Call Control Signaling
- Call Authorization

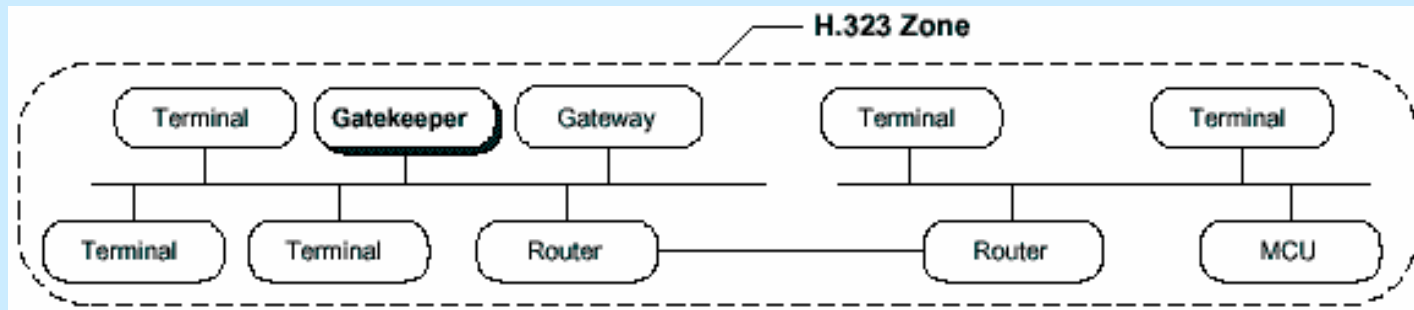

*H.323 Primer

Component - Gateway

Function performed by Gateway:

- Translation function between H.323 conferencing endpoints and other terminals
- Translates between audio and video
- Terminals communicate with Gateways using the H.245 and Q.931 protocols.
- Not required in LAN.

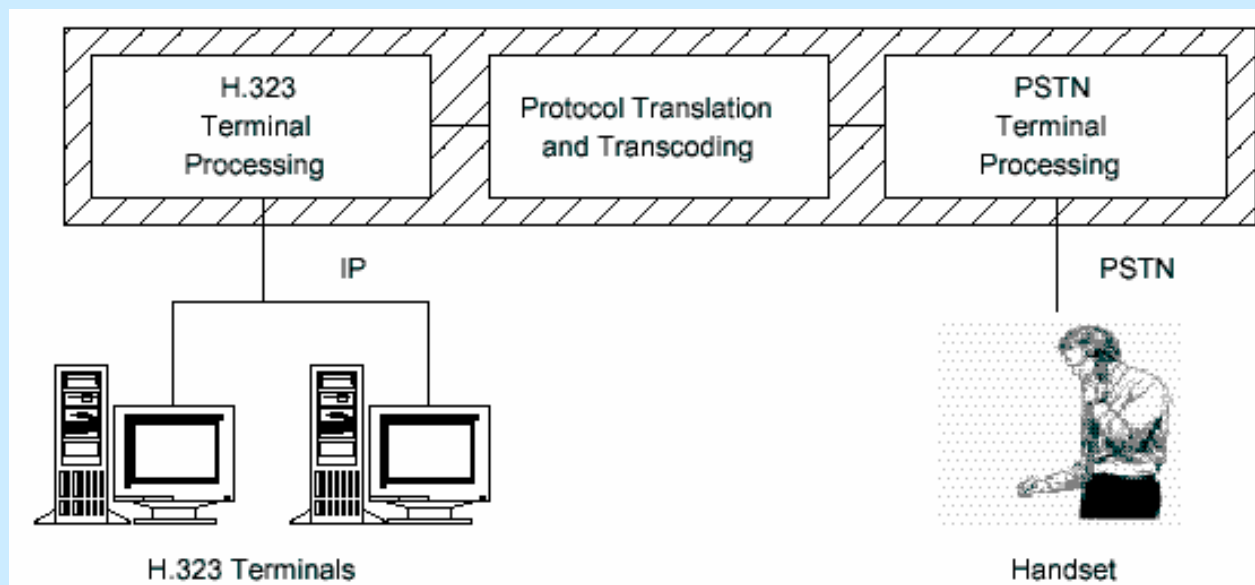

*H.323 Primer

H.323 Network Elements

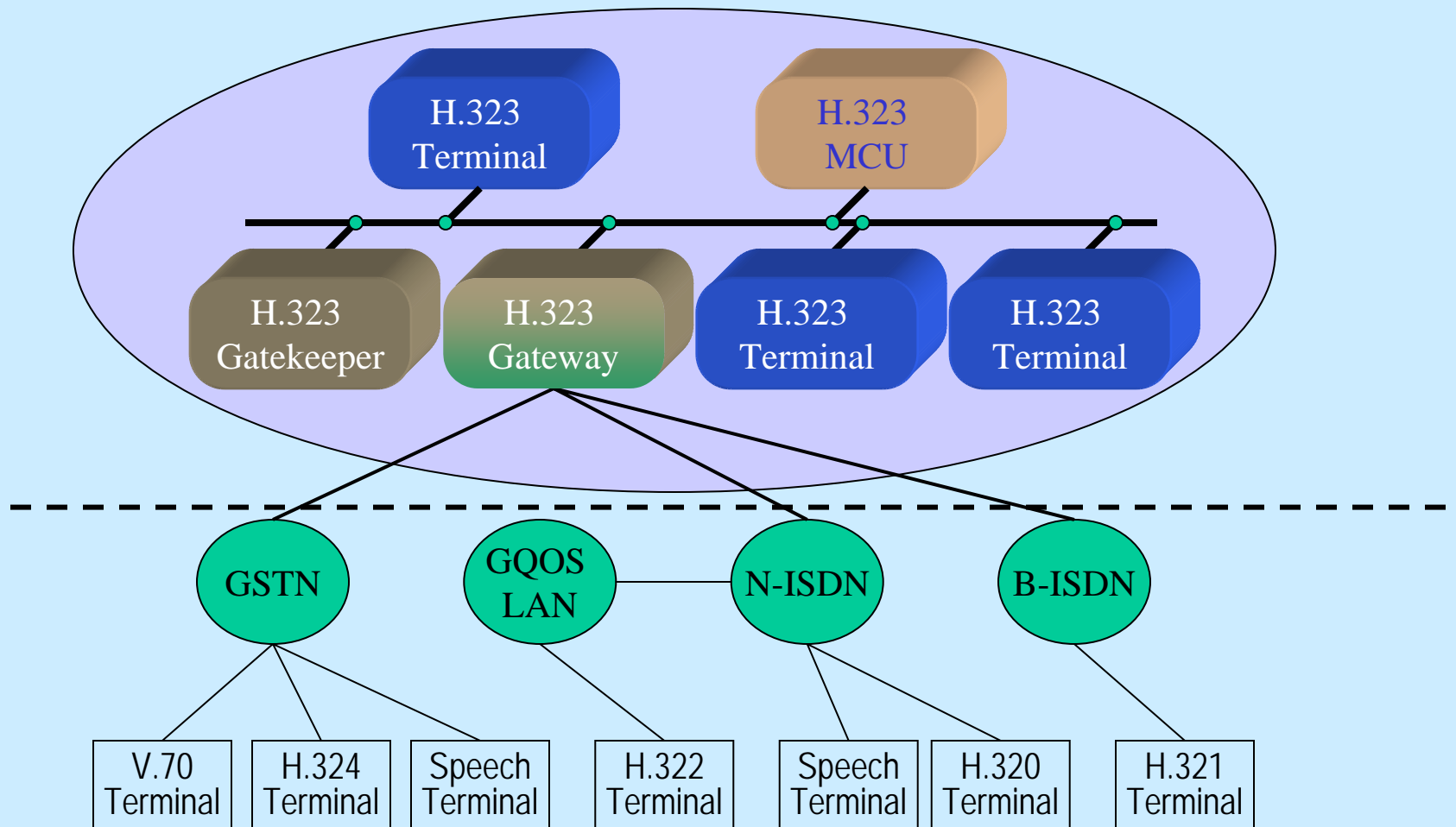

Phone-to-Phone via the Internet

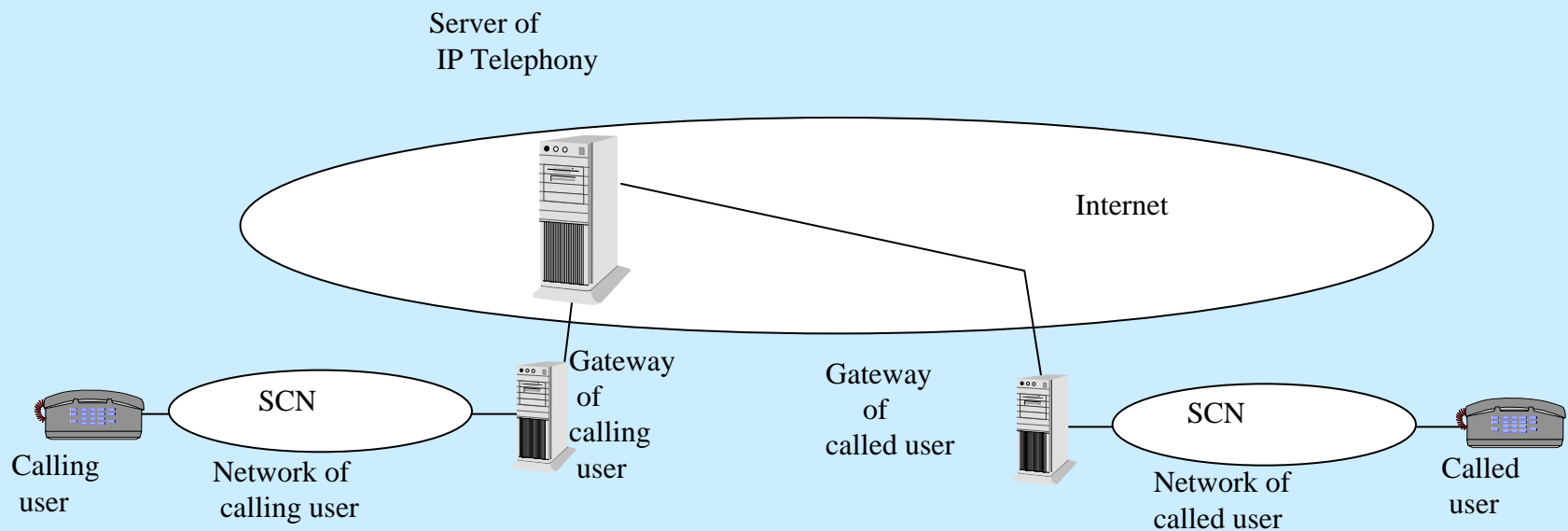

IP Telephony Class1 connection
(Phone-to-Phone via the Internet)

Phone-to-PC in the Internet

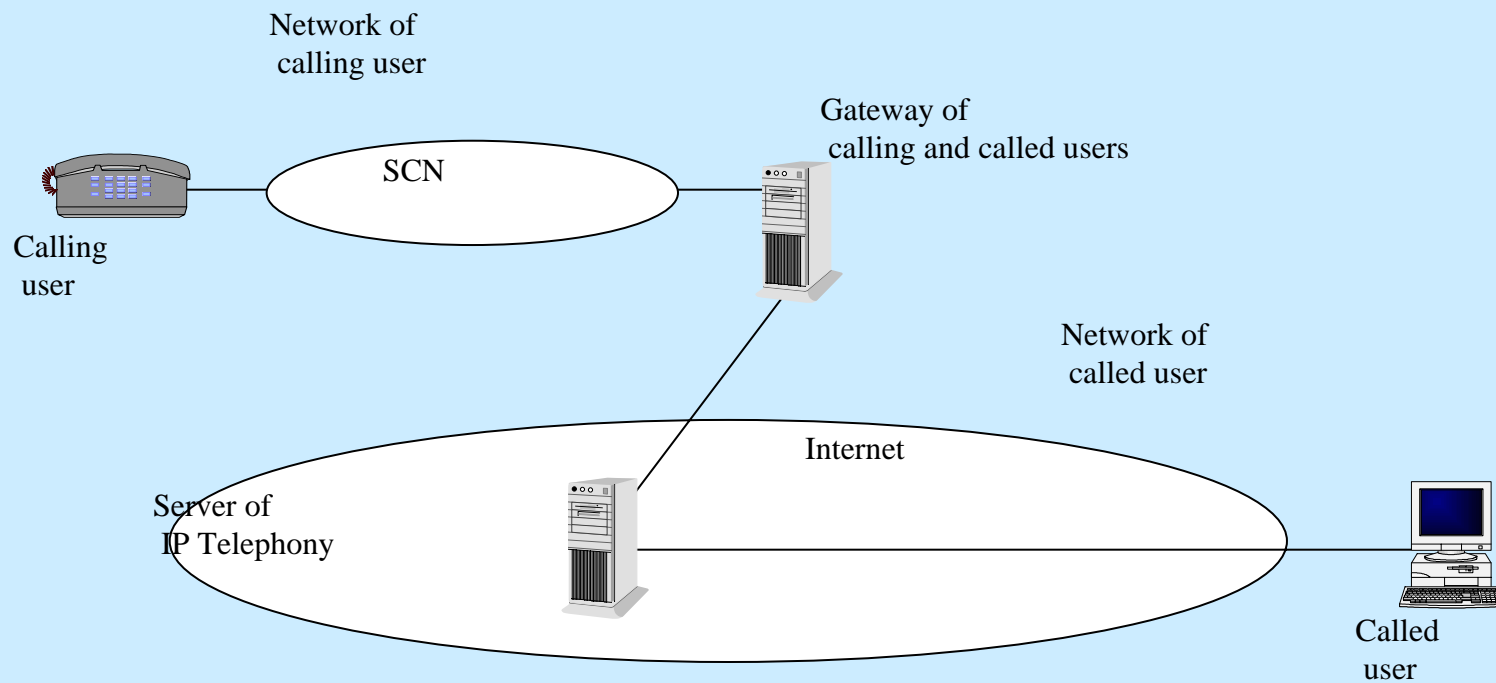

IP Telephony Class2-1 connection
(Phone-to-PC in the Internet)
Internet Telephony

PC in the Internet-to-Phone

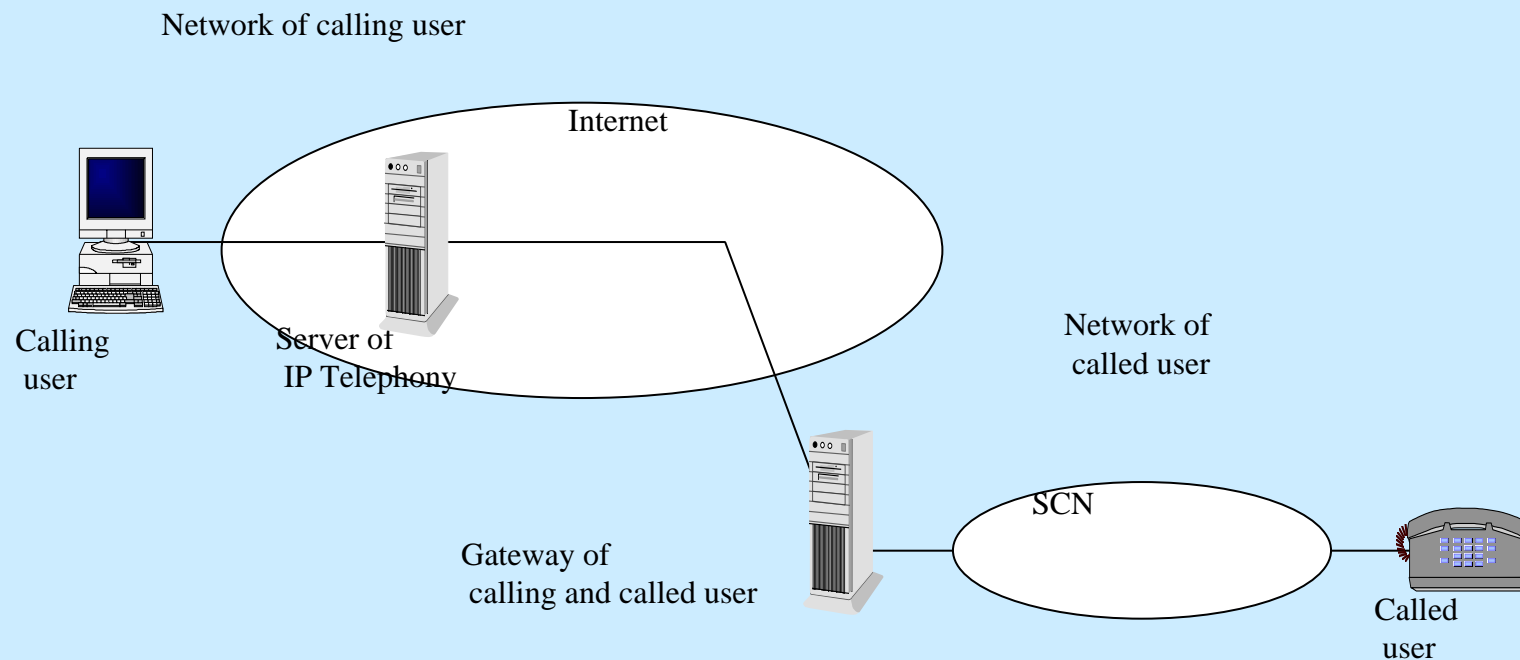

IP Telephony Class2-2 connection
(PC in the Internet-to-Phone)

PC-to-PC in the Internet

Network of calling user and called user

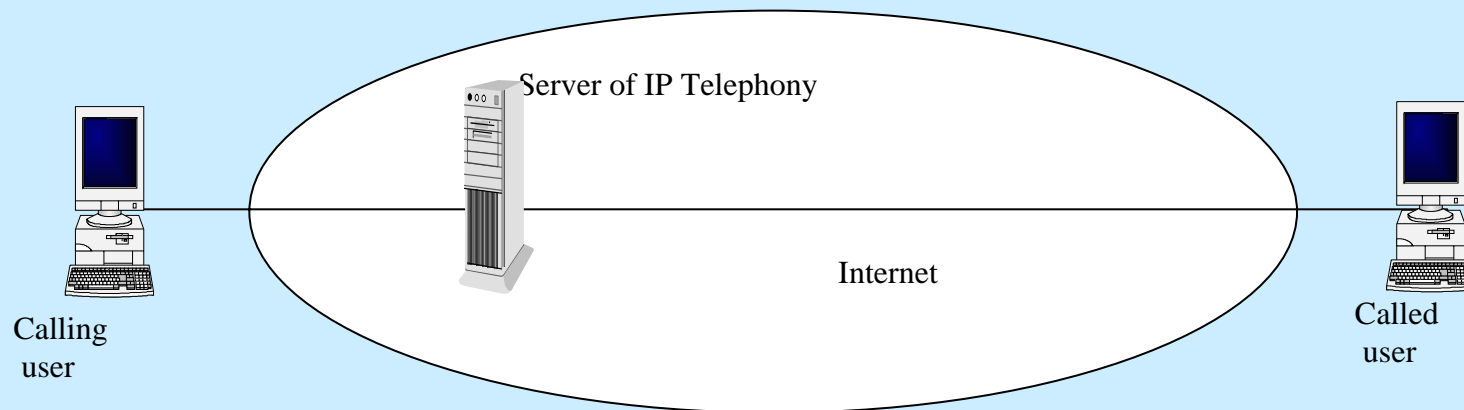

IP Telephony Class3 connection
(PC-to-PC in the Internet)

Internet Telephony

PC in the Internet-to-PC in the separate IP-based network via SCN

Network of calling user

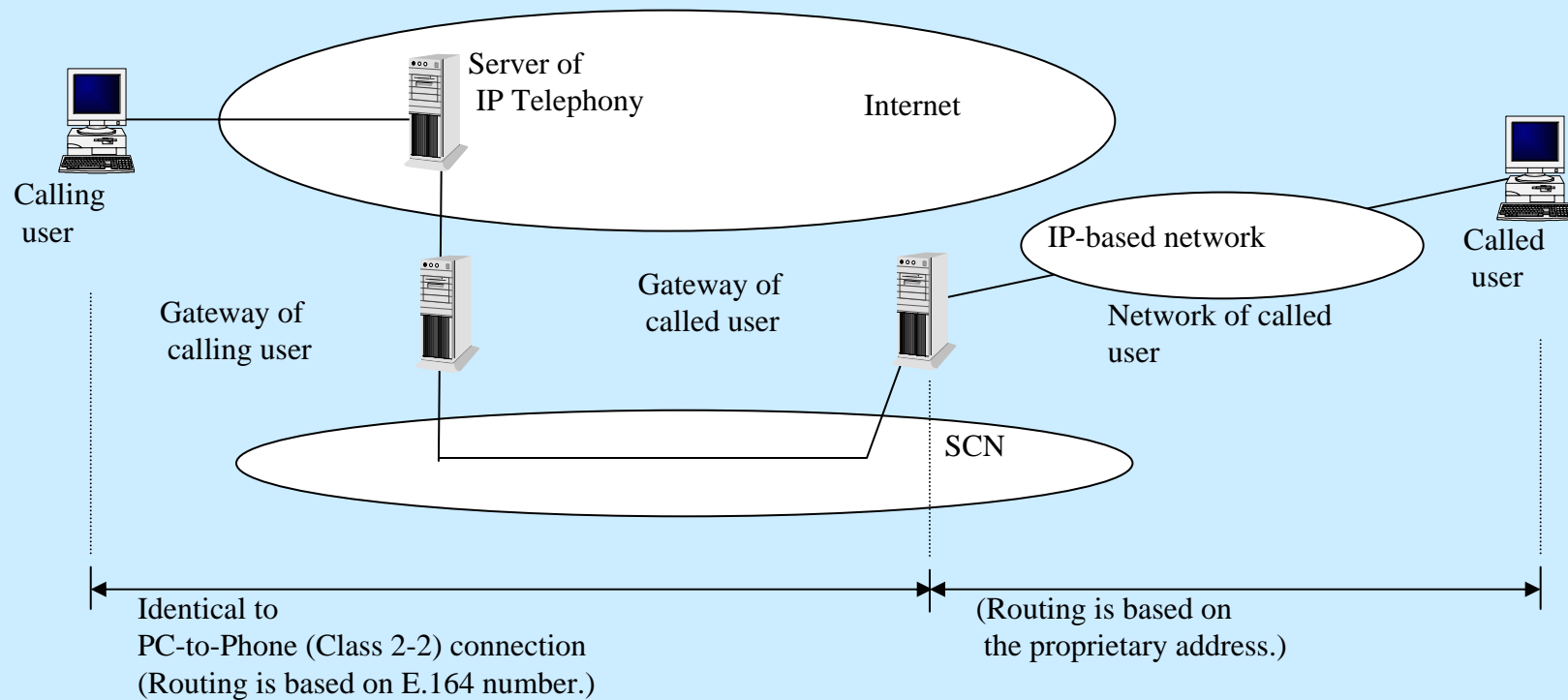

A part of path in Class 4-1 connection is identical to the path in PC-to-Phone (Class 2-2) connection

PC in the separate IP-based network-to-PC in the Internet via SCN

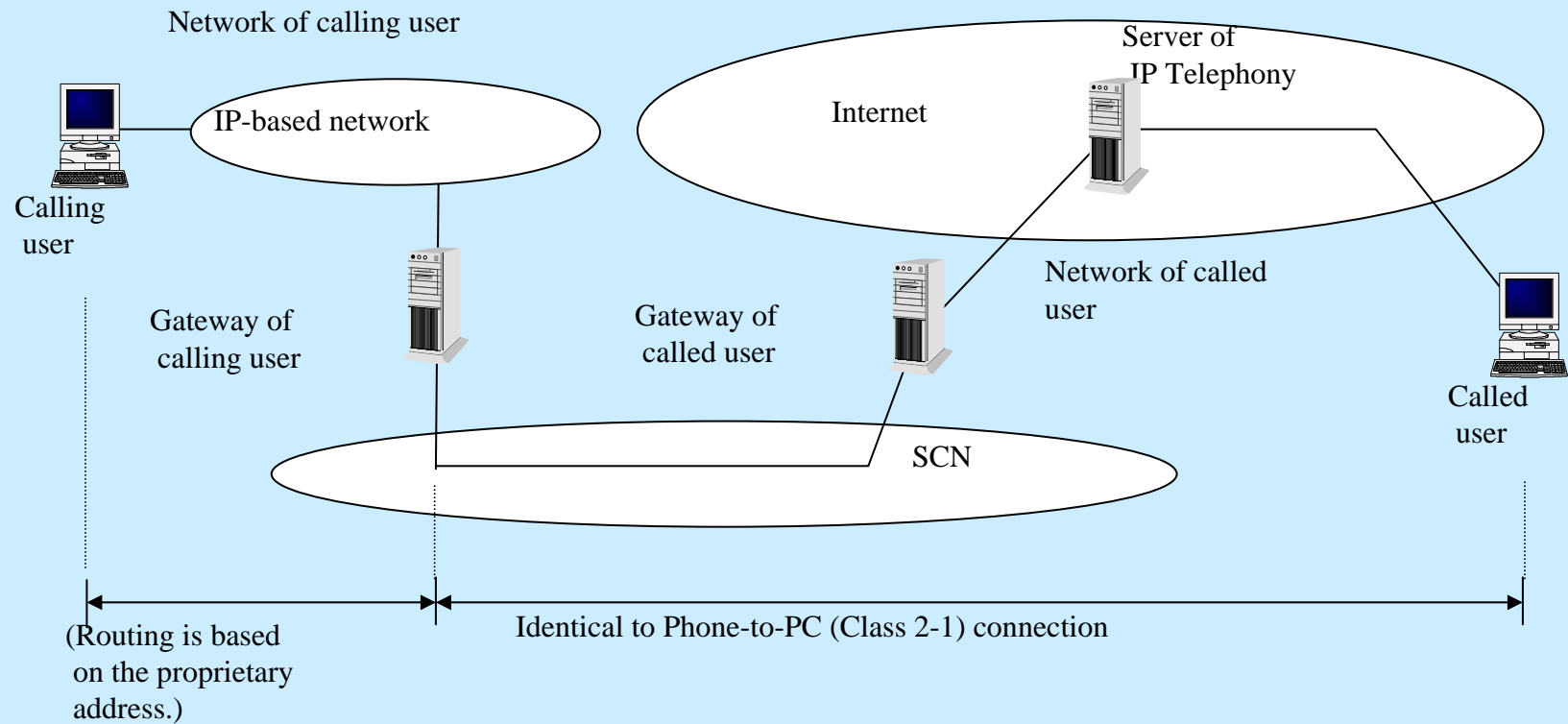

IP Telephony Class 4-2 connection
 (PC in the separate IP-based network-to-PC in the Internet via SCN)
 Internet Telephony

PC-to-PC via SCN

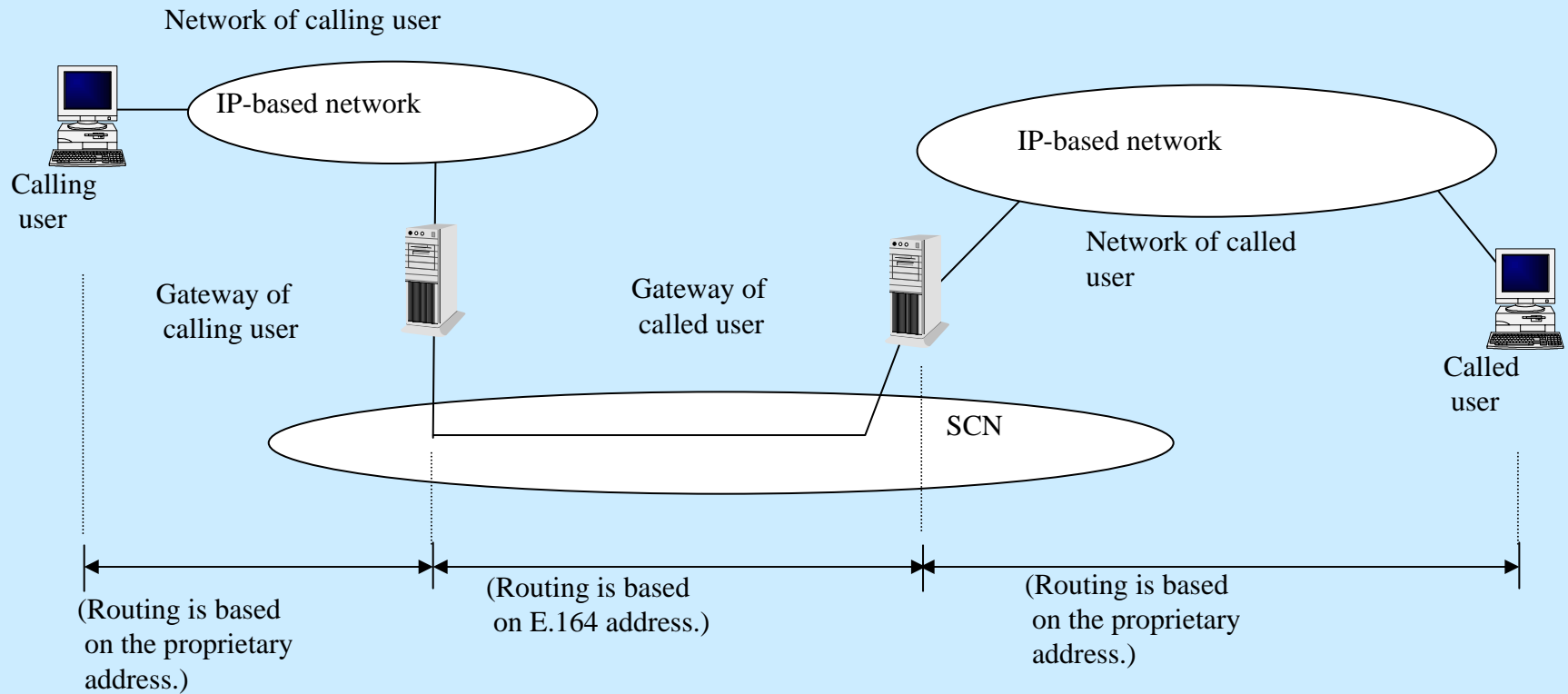

IPT Management Requirements

- **Pre-Deployment Assessment**
- **Post-Deployment QoS Monitoring**
- **Performance from the End-User Perspective**
- **Managing Security**
- **Troubleshooting**
- **Automated Management**
- **Call Management**

Conclusion

- Internet Telephony is a powerful and economical communication options which is gaining its popularity
- The most significant obstacles in reaching the height of success is the unsatisfactory voice quality and the lack of means of commercial deployments. Both of them are under investigation. The voice quality will increase with special QoS means and generic increasing bandwidth. Commercial deployment should be designed by both, commercial and academic world.
- The standard for addressing a millions of PSTN user should be made so that they can be able to use it. Simultaneously Internet telephony systems that are currently deployed should be maintains and managed so that they will encourage others for deploying internet telephony.